

TEHNIČKI LIST

KRIVINA UNUTRAŠNJA ČETVRTASTA

WH-WRIH



W Aluminijum – Natur

Dimenzije [mm]					
Nominalna veličina	A	B	C	ØD	L
250	55	85	65	18	285
333	75	120	85	20	275

INDEKS	SMENA	DATUM	POTPIS			
MARKA MAT.						
DIM.-POLUPROIZVOD					STN	BROJ KAT.
PROPORCIJE UREĐAJA					BELEŠKA	BR.POZICIJE
IZRADIO Ing. Kluska M.					STARI CRTEŽ	BR.CRTEŽA
PROVERIO						
TEHNOL.		TEHNOL.				
NAZIV Krivina unutrašnja četvrtasta				Broj listova	WH-WRIH	List 

Kreirano: 06.06.2026 23:21:57

Tehničke promene moguće

TEHNIČKI LIST

KRIVINA UNUTRAŠNJA ČETVRTASTA

WH-WRIH

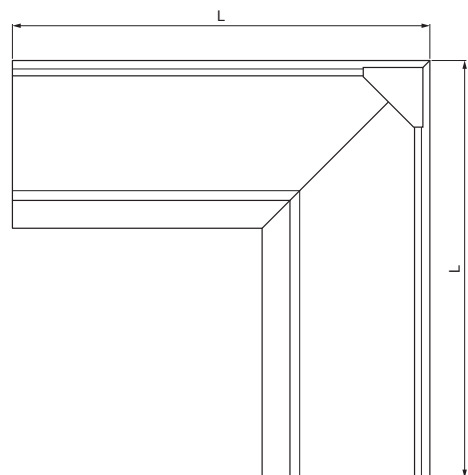
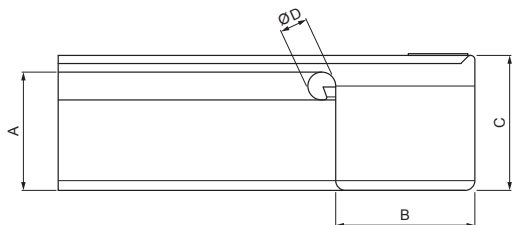

W Aluminijum – Natur

INDEKS	SMENA	DATUM	POTPIS			
MARKA MAT.						
DIM.–POLUPROIZVOD						
PROPORCIJE UREĐAJA					STN	BROJ KAT.
IZRADIO	Ing. Kluska M.			BELEŠKA	BR.POZICIJE	
PROVERIO						
TEHNOL.		TEHNOL.		STARI CRTEŽ	BR.CRTEŽA	
NAZIV				WH-WRIH		
Krivina unutrašnja četvrtasta				Broj listova	List	

Kreirano: 06.06.2026 23:21:57

Tehničke promene moguće

Dimenzije [mm]					
Nominalna veličina	A	B	C	ØD	L
400	90	150	100	22	400