

TEHNIČKI LIST

# KRIVINA UNUTRAŠNJA ČETVRTASTA

## W.15H-WRIH

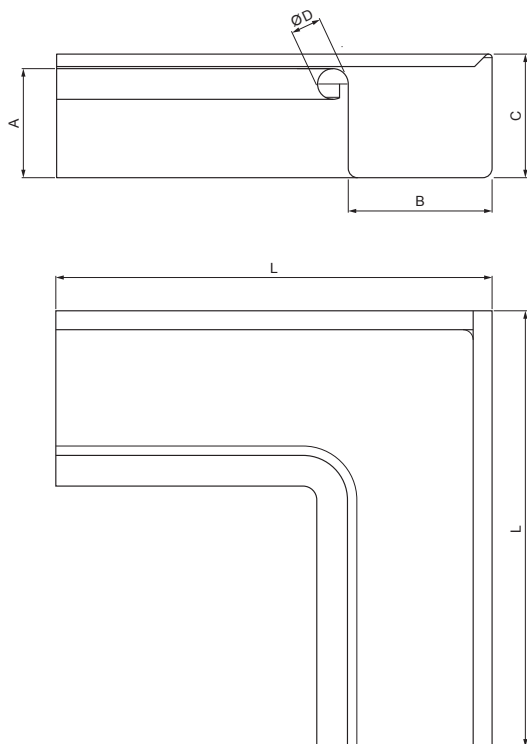

**ANM** Aluminijum obojeni W.15 – Antracit W.15 – RAL 7016

INDEKS	SMENA	DATUM	POTPIS	<b>KJG</b> QUALITY®	Scan code for 3D model 
MARKA MAT.					
DIM.-POLUPROIZVOD			K.O.	STN	BROJ KAT.
PROPORCIJE UREĐAJA				BELEŠKA	BR.POZICIJE
IZRADIO	Ing. Kluska M.			STARI CRTEŽ	BR.CRTEŽA
TEHNOL.		TEHNOL.		STARI CRTEŽ	BR.CRTEŽA
NAZIV Krivina unutrašnja četvrtasta				Broj listova	W.15H-WRIH List 

Kreirano: 22.04.2026 11:06:03

Tehničke promene moguće

Dimenzije [mm]					
Nominalna veličina	A	B	C	ØD	L
250	55	85	65	18	285
333	75	120	85	20	275

TEHNIČKI LIST

# KRIVINA UNUTRAŠNJA ČETVRTASTA

## W.15H-WRIH

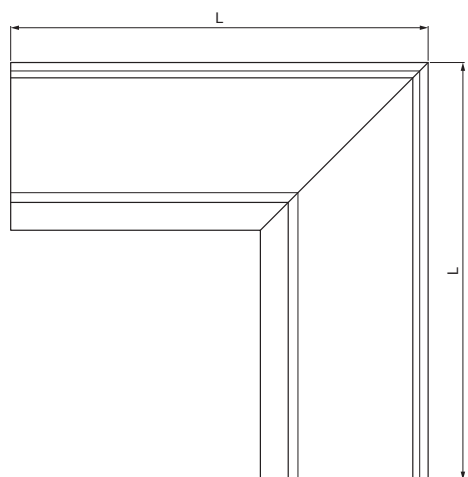
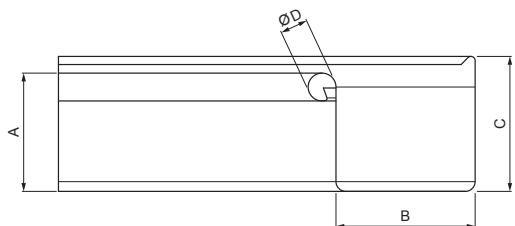

**ANM** Aluminijum obojeni W.15 – Antracit W.15 – RAL 7016

INDEKS	SMENA	DATUM	POTPIS			
MARKA MAT.		K.O.	TEŽINA kg			
DIM.–POLUPROIZVOD						
PROPORCIJE UREĐAJA.				STN	BROJ KAT.	
IZRADIO	Ing. Kluska M.			BELEŠKA	BR.POZICIJE	
PROVERIO						
TEHNOL.	TEHNOL.			STARI CRTEŽ	BR.CRTEŽA	
NAZIV				Broj listova      W.15H-WRIH      List		
Krivina unutrašnja četvrtasta						

Kreirano: 22.04.2026 11:06:03

Tehničke promene moguće

Dimenzije [mm]					
Nominalna veličina	A	B	C	ØD	L
400	90	150	100	22	400