

TEHNIČKI LIST

# KROVNI STEPENIK ZA KROVNI POKRIVAČ UNI

# UNI-DACH

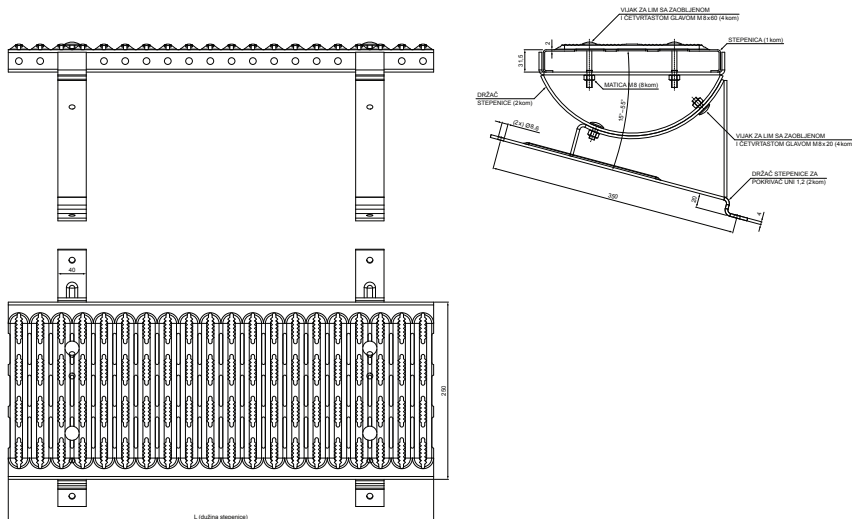

**DETALJ:**

1. krovni stepenik za krovni pokrivač UNI
2. spojnica platforme sa krovnim stepenikom
3. vijak farmer 4,8x60
4. EPDM podloška 25x40x3
5. krovni pokrivač
6. krovne letve
7. letve
8. rafter
9. uvodni lim
10. zaštitni ventilacioni pojas
11. folija
12. oluk polukružni
13. kuka

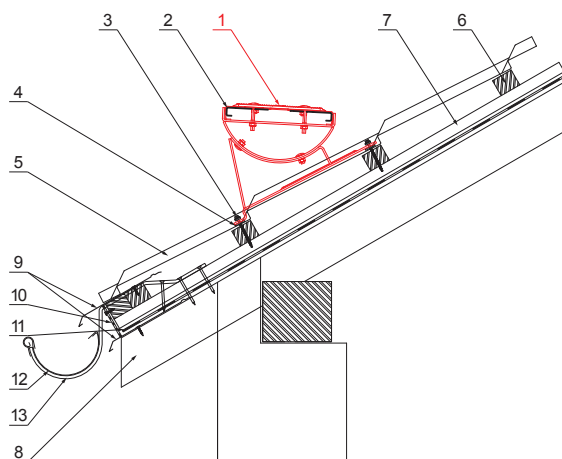

**OC** Pocink obojeni – Vinsko crvena – RAL 3009

INDEKS	SMENA	DATUM	POTPIS	 
MARKA MAT.		K.O.	TEŽINA kg	
DIM.–POLUPROIZVOD				
PROPORCIJE UREĐAJA			STN	BROJ KAT.
IZRADIO Ing. Kluska M.			BELEŠKA	BR.POZICIJE
PROVERIO			STARI CRTEŽ	BR.CRTEŽA
TEHNOL.	TEHNOL.		STARI CRTEŽ	BR.CRTEŽA
NAZIV	Krovni stepenik za krovni pokrivač UNI		Broj listova	UNI-DACH List 

Kreirano: 07.06.2026 10:42:25

Tehničke promene moguće

Dimenzije [mm]	
Nominalna veličina	L
600	600
800	800

TEHNIČKI LIST

# KROVNI STEPENIK ZA KROVNI POKRIVAČ UNI

# UNI-DACH

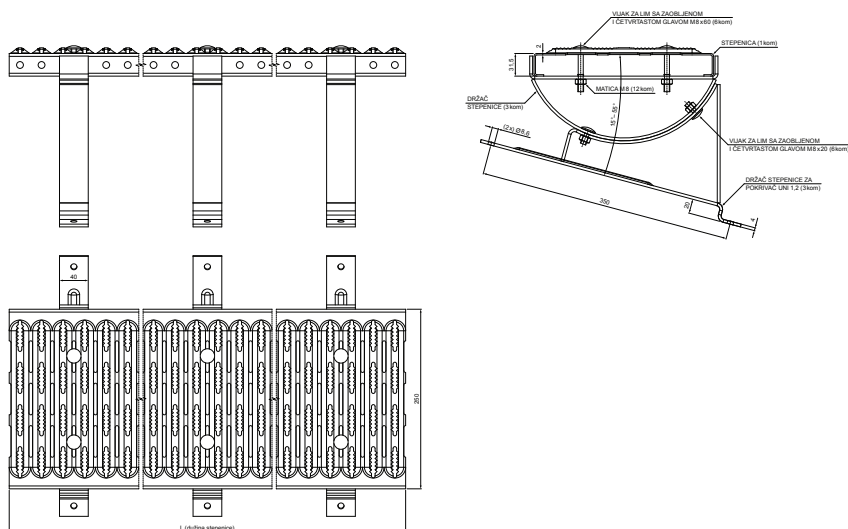

**DETALJ:**

1. krovni stepenik za krovni pokrivač UNI
2. spojnica platforme sa krovnim stepenikom
3. vijak farmer 4,8x60
4. EPDM podloška 25x40x3
5. krovni pokrivač
6. krovne letve
7. letve
8. rafter
9. uvodni lim
10. zaštitni ventilacioni pojas
11. folija
12. oluk polukružni
13. kuka

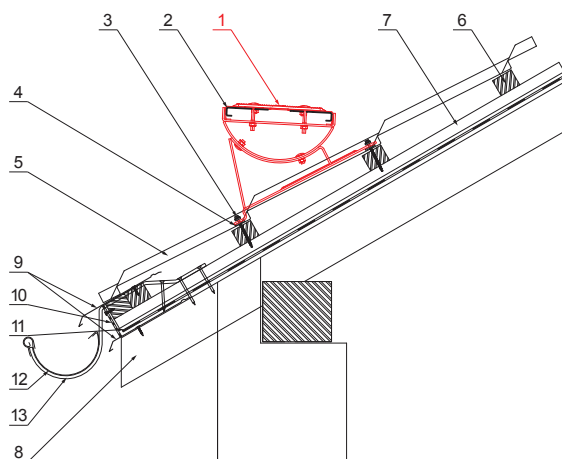

**OC** Pocink obojeni – Vinsko crvena – RAL 3009

INDEKS	SMENA	DATUM	POTPIS	 	
MARKA MAT.		K.O.	TEŽINA kg		RAZMERE
DIM.-POLUPROIZVOD				STN	BROJ KAT.
PROPORCIJE UREĐAJA				BELEŠKA	BR.POZICIJE
IZRADIO	Ing. Kluska M.				
PROVERIO					
TEHNOL.	TEHNOL.		STARI CRTEŽ		BR.CRTEŽA
NAZIV		Krovni stepenik za krovni pokrivač UNI		Broj listova	UNI-DACH List

Kreirano: 07.06.2026 10:42:25

Tehničke promene moguće

Dimenzije [mm]	
Nominalna veličina	L
1200	1200