

TEHNIČKI LIST

OSNOVNA MONTAŽNA PLOČA

FALZ-HEU MP ZPL

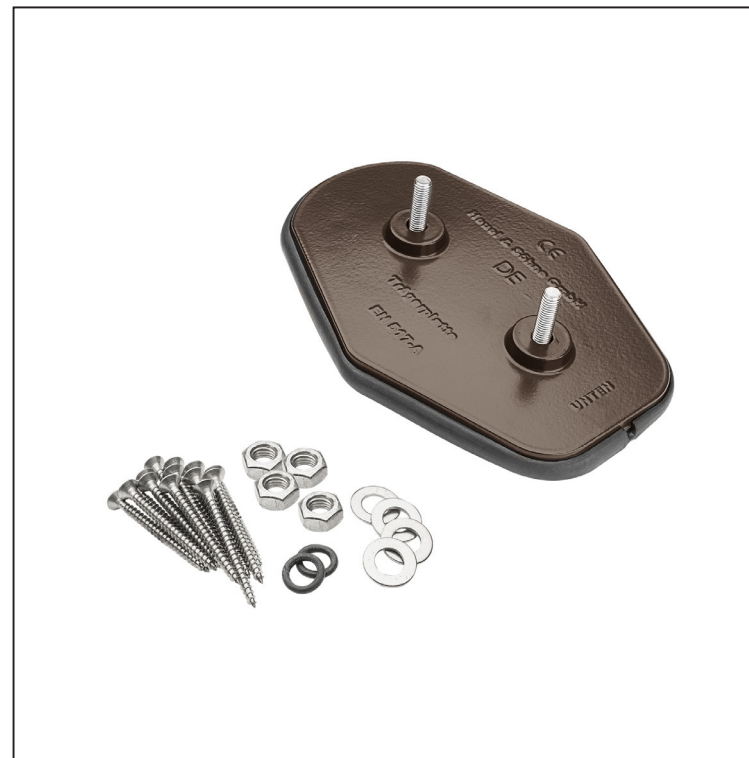
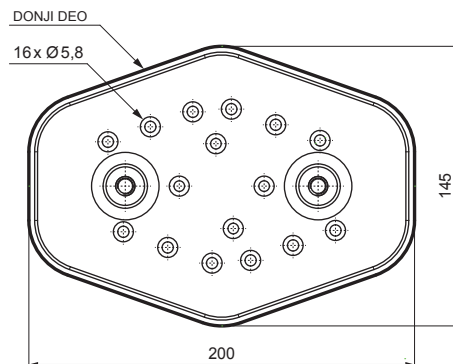
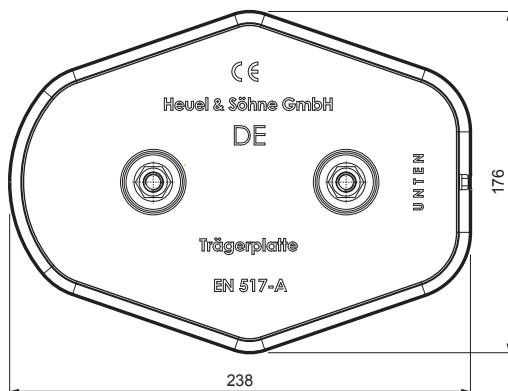
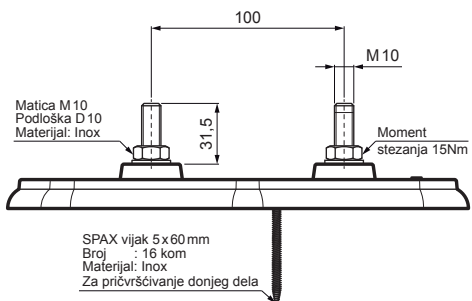

DETALJ:

1. osnovna montažna ploča

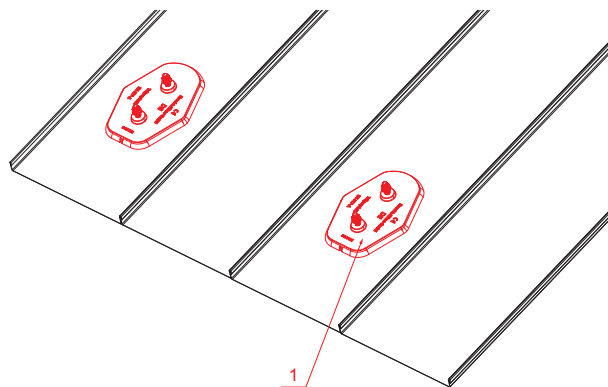

TM Aluminijum obojeni – Testa di Moro – RAL 8028

INDEKS	SMENA	DATUM	POTPIS		
MARKA MAT.					
DIM.-POLUPROIZVOD			K.O.	STN	BROJ KAT.
PROPORCIJE UREĐAJA				BELEŠKA	BR.POZICIJE
IZRADIO Ing. Kluska M.				STARI CRTEŽ	BR.CRTEŽA
PROVERIO		TEHNOL.		NAZIV	
Osnovna montažna ploča			Broj listova	FALZ-HEU MP ZPL List	

Kreirano: 07.06.2026 22:05:36

Tehničke promene moguće