

TEHNIČKI LIST

OSNOVNA MONTAŽNA PLOČA

FALZ-HEU MP ZPL

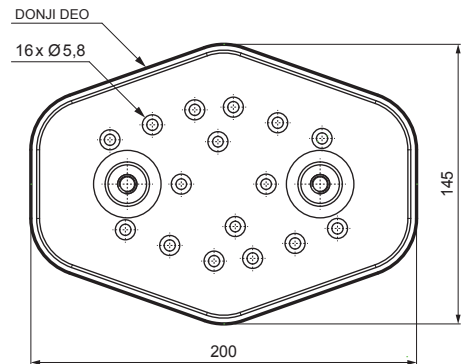
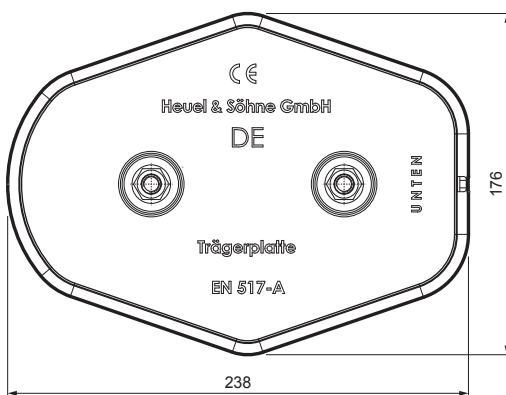
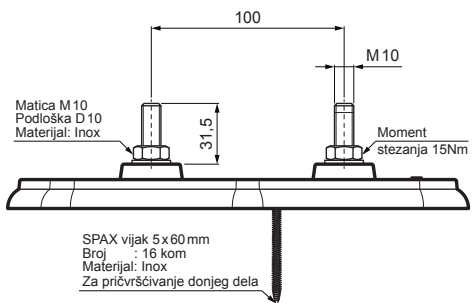

DETALJ:
1. osnovna montažna ploča

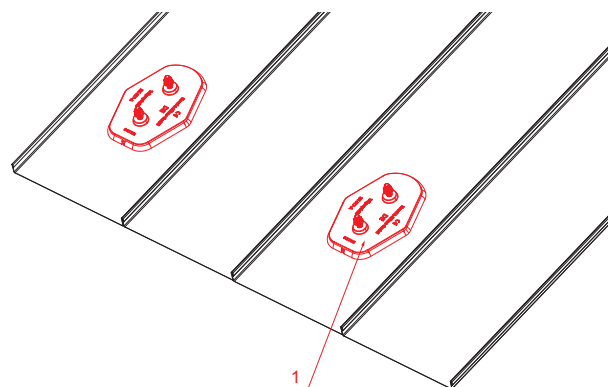

ANM Aluminijum obojeni W.15 – Antracit W.15 – RAL 7016

INDEKS	SVIENA	DATUM	POTPIS		
MARKA MAT.					
DIM.-POLUPROIZVOD			K.O.	STN	BROJ KAT.
PROPORCIJE UREĐAJA				BELEŠKA	BR.POZICIJE
IZRADIO	Ing. Kluska M.			STARI CRTEŽ	BR.CRTEŽA
PROVERIO		TEHNOL.			
NAZIV			Osnovna montažna ploča Broj listova FALZ-HEU MP ZPL List		