

TEHNIČKI LIST

# OSNOVNA MONTAŽNA PLOČA

# FALZ-HEU MP ZPL

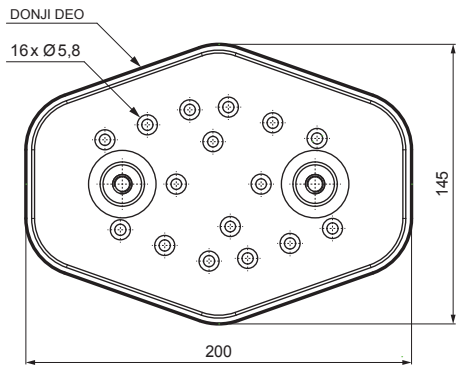
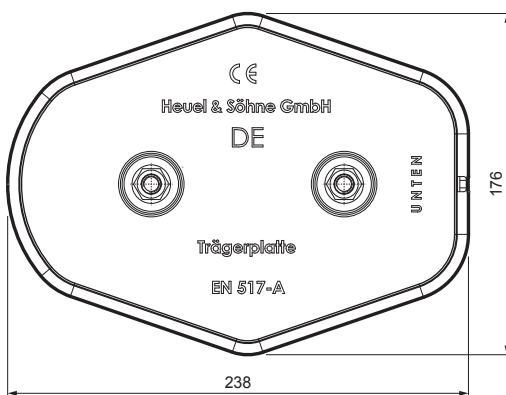
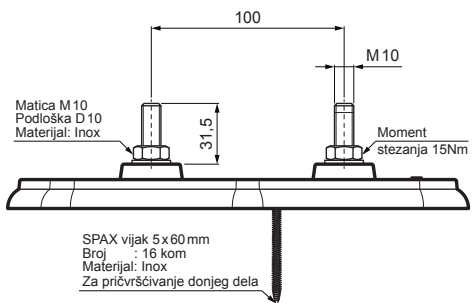

**DETALJ:**  
1. osnovna montažna ploča

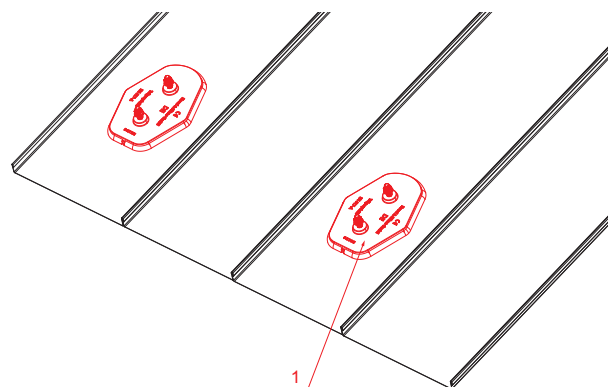

**TMM** Aluminijum obojeni W.15 – Testa di Moro W.15 – RAL 8028

INDEKS	SVIENA	DATUM	POTPIS		
MARKA MAT.					
DIM.-POLUPROIZVOD					
PROPORCIJE UREĐAJA				STN	BROJ KAT.
IZRADIO	Ing. Kluska M.			BELEŠKA	BR.POZICIJE
PROVERIO					
TEHNOL.	TEHNOL.			STARI CRTEŽ	BR.CRTEŽA
NAZIV				List	
Osnovna montažna ploča				Broj listova	FALZ-HEU MP ZPL

Kreirano: 07.06.2026 12:23:18

Tehničke promene moguće