

TEHNIČKI LIST

EKSER ZA ČELIČNU KONSTRUKCIJU SA GLAVOM OD 10 mm

SM-OKCSS-H10

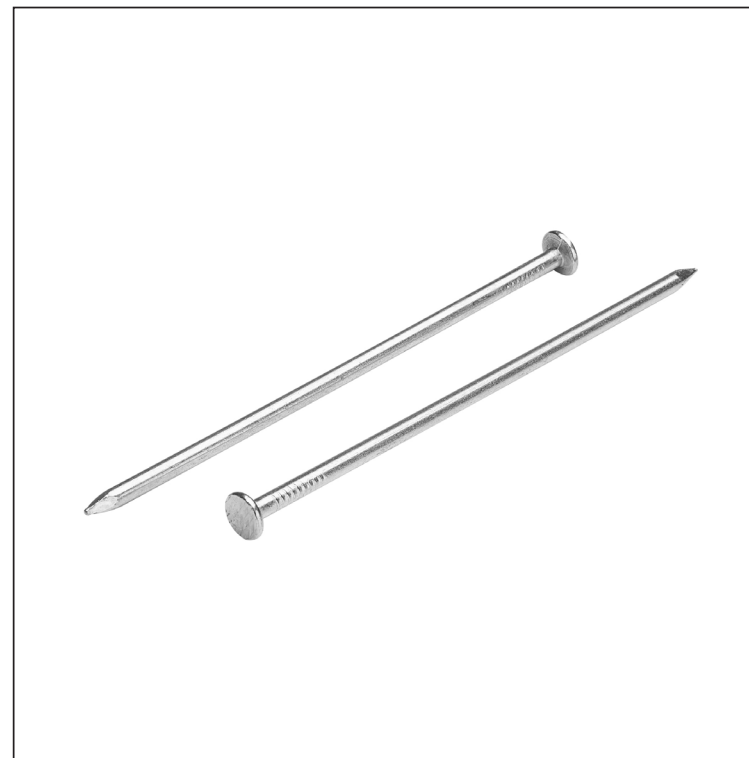
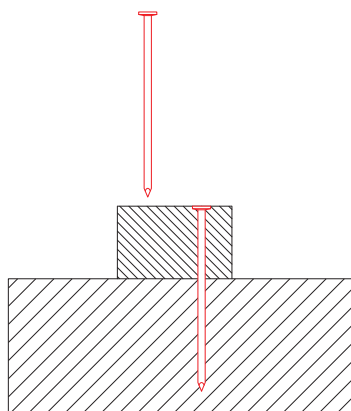
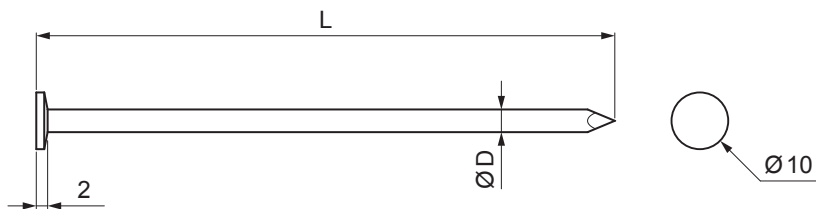

Čelik

Dimenzije [mm]		
Nominalna veličina	Ø D	L
28/63	2,8	63
28/70	2,8	70
31/80	3,1	80
35/90	3,5	90
40/100	4,0	100
40/120	4,0	120
50/150	5,0	150
71/220	7,1	220
88/300	8,8	300

INDEKS	SMENA	DATUM	POTPIS		
MARKA MAT.	K.O.		TEŽINA kg		
DIM.-POLUPROIZVOD			STN	BROJ KAT.	
PROPORCIJE UREĐAJA.			BELEŠKA	BR.POZICIJE	
IZRADIO Ing. Kluska M.			STARI CRTEŽ	BR.CRTEŽA	
PROVERIO	TEHNOL.		NAZIV Ekser za čeličnu konstrukciju sa glavom od 10 mm		
			Broj listova	SM-OKCSS-H10	List

Kreirano: 06.06.2026 09:26:50

Tehničke promene moguće