

TEHNIČKI LIST

INOX VIJKA ZA ŠELNE M8x30

P-POB-NSK

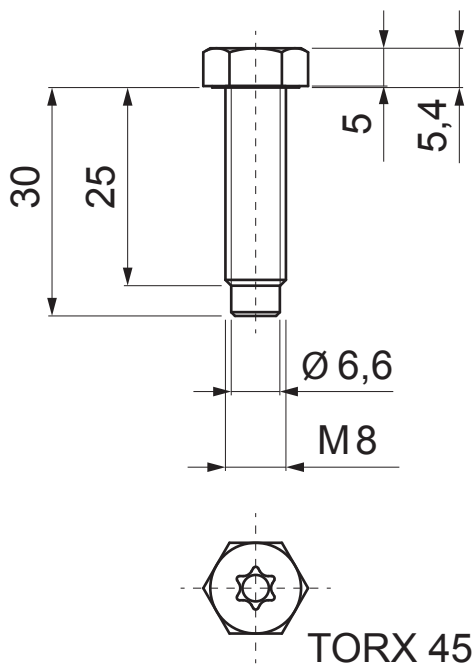

304 2B Inox – AISI 304 2B – MATT

INDEKS	SMENA	DATUM	POTPIS			
MARKA MAT.						K.O.
DIM.-POLUPROIZVOD					STN	BROJ KAT.
PROPORCIJE UREĐAJA.					BELEŠKA	BR.POZICIJE
IZRADIO Ing. Kluska M.						
PROVERIO						
TEHNOL.		TEHNOL.		STARI CRTEŽ	BR.CRTEŽA	
NAZIV				Broj listova P-POB-NSK List 		
Inox vijka za šelne M8x30						

Kreirano: 04.06.2026 11:09:16

Tehničke promene moguće